

48" | 1219_{mm}
Davit Arm
With Adapters

Davit arm equipped with a bracket for the self-retracting lifeline and winch to ease access and rescue in confined spaces. Made to guarantee a safer working environment.



XTIRPA™

48" | 1219mm

Davit Arm

With Adapters



Assembling scheme

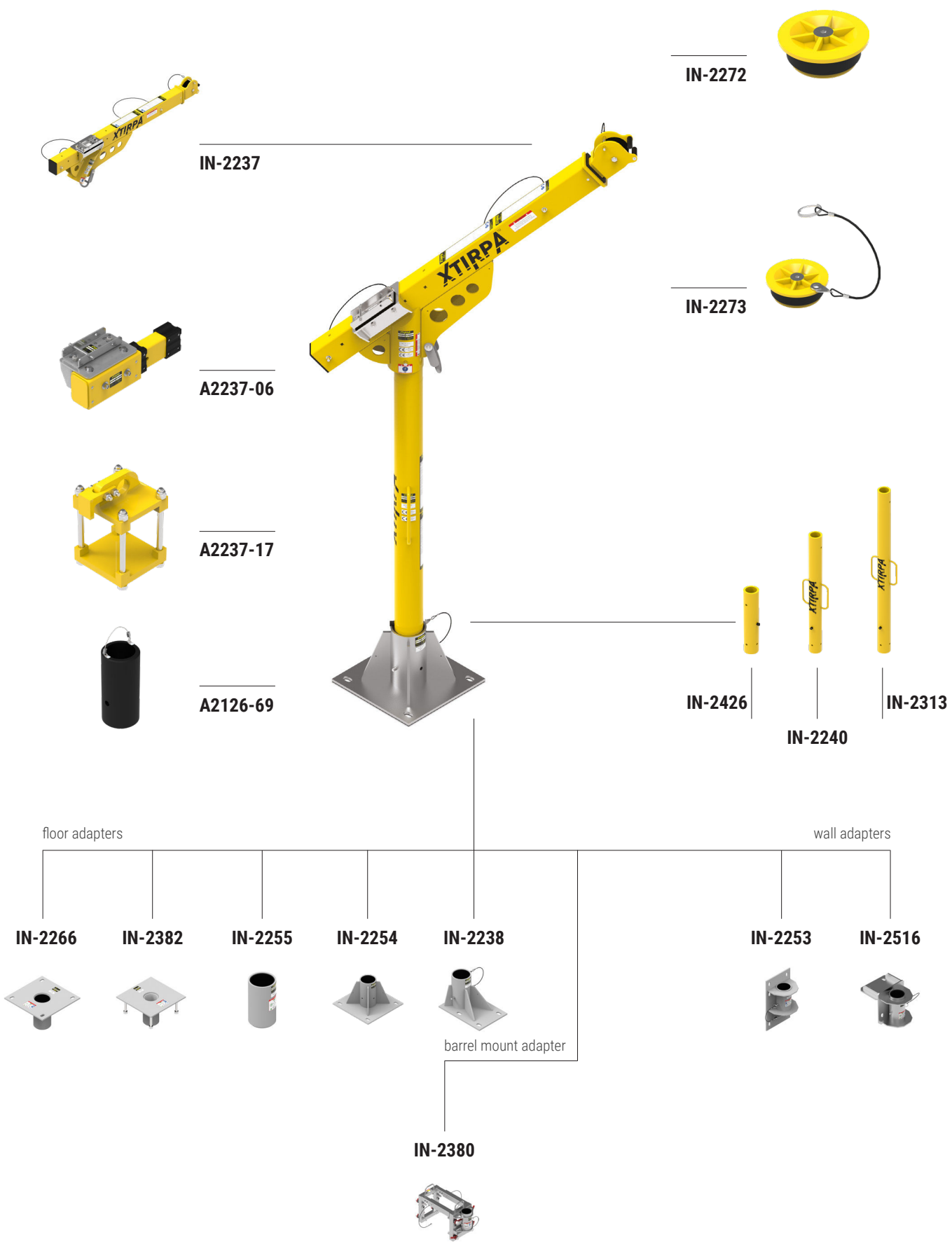

XTIRPA™

IN-2237 Davit Arm 1219 mm



Equipped with bracket for self-retracting lifeline to facilitate access to confined spaces. Compatible with mast IN-2426 or IN-2240 or IN-2313 and an appropriate adapter. Extensible to 30", 36" and 48" (762 mm, 914 mm and 1219 mm). Equipped with a 22kN anchor point.

Material:
Aluminium

Dimensions:
L 56"-77" (1422-1965mm)
W 6.8" (172 mm)
H 38.5"-52.2" (977-1326 mm)

Weight:
50 lb (23 kg)



IN-2426 / IN-2240 / IN-2313 Mast

Compatible with davit arm IN-2237 and corresponding adapters or with a counterweight system.

| Part | Length | Weight |
|---------|---------------|-----------------|
| IN-2426 | 20" (500 mm) | 11 lb (5 kg) |
| IN-2240 | 42" (1067 mm) | 23 lb (10.4 kg) |
| IN-2313 | 60" (1521 mm) | 34 lb (15.4 kg) |

Material: Aluminium

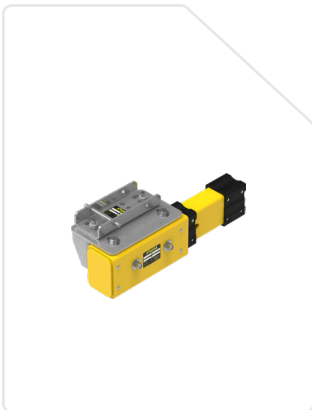

A2237-06 Removable winch adapter

To be used for the installation of a winch or an additional retractable lifeline on the 48" (1219 mm) davit arm IN-2237.

Material: Aluminium

Dimensions: L 16" (412 mm) x W 6" (158 mm) x H 6.2" (163 mm)

Weight: 15 lb (7 kg)

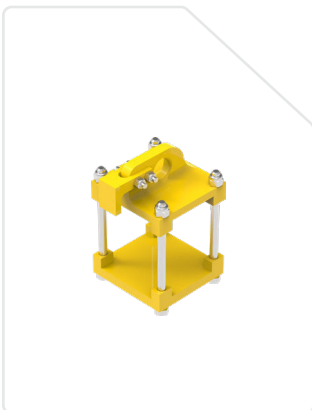

A2237-17 Auxiliary fall protection anchor point

Auxiliary fall protection anchor point to be mounted on the 48" (1219 mm) davit arm IN-2237.

Material: Aluminium

Dimensions: L 5" (127 mm) x W 4.1" (105 mm) x H 6.8" (172 mm)

Weight: 3 lb (1.4 kg)

48" | 1219_{mm}

Davit Arm

With Adapters



IN-2266

Flush floor adapter for concrete and steel

Compatible with mast IN-2426 or IN-2240 or IN-2313 and 48" (1219 mm) davit arm IN-2237 on existing concrete or steel structures. Anchor bolts not included.

*Allowable working angle.

Material: AISI 304 stainless steel

Dimensions: L 15" (381 mm) x W 15" (381 mm) x H 9.4" (238 mm)

Weight: 33 lb (15 kg)



IN-2382

Fresh concrete floor adapter

Compatible with mast IN-2426 or IN-2240 or IN-2313 and 48" (1219 mm) davit arm IN-2237 when laying concrete for new constructions.

*Allowable working angle.

Material: AISI 304 stainless steel

Dimensions: L 15" (381 mm) x W 15" (381 mm) x H 9.4" (239 mm)

Weight: 42 lb (19 kg)



IN-2255

Core mount adapter for concrete

Compatible with mast IN-2426 or IN-2240 or IN-2313 and 48" (1219 mm) davit arm IN-2237.

*Allowable working angle.

Material: AISI 304 stainless steel

Dimensions: ø 5" (127 mm) x H 9.1" (232 mm)

Weight: 12 lb (5.4 kg)

IN-2272 Cap

Used when the mast is not inserted to prevent objects from falling inside the adapters.

Material: Rubber and plastic
Dimensions: : ϕ 4.3" (109.2 mm) x H 2" (50.8 mm)
Weight: 0.4 lb (0.22 kg)



IN-2273 Cap with steel cable

Used when the mast is not inserted to prevent objects from falling inside the adapters.
This version comes with steel cable.

Material: Rubber and plastic
Dimensions: ϕ 4.3" (109.2 mm) x H 2" (50.8mm)
Weight: 0.5 lb (0.22 kg)



IN-2254

Central floor adapter for concrete and steel

Compatible with mast IN-2426 or IN-2240 or IN-2313 and 48" (1219 mm) davit arm IN-2237.
Allows fixed and multiple working angles every 90°.
Anchor bolts not included. *Allowable working angle.

Material: AISI 304 stainless steel also available in zinc plated steel (IN-2304) /
AISI 316 (IN-2451) and galvanized (IN-2529)
Dimensions: L 15" (381 mm) x W 15" (381 mm) x H 9.25" (235 mm)
Weight: 45 lb (20 kg)

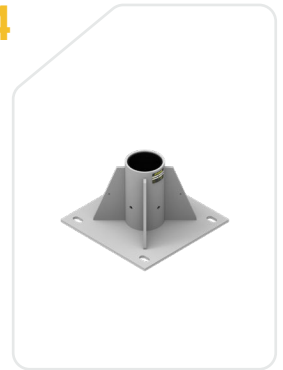

IN-2238

Floor adapter for concrete and steel

Compatible with mast IN-2426 or IN-2240 or IN-2313 and 48" (1219 mm) davit arm IN-2237
on existing concrete or steel structures. Increases the range of the system by installing it near the edge of the structure.
Anchor bolts not included. *Allowable working angle.

Material: AISI 304 stainless steel also available in zinc plated steel (IN-2302) /
AISI 326 (IN-2452) and galvanized (IN-2527)
Dimensions: L 14.5" (368 mm) x W 10" (254 mm) x H 9.25" (235 mm)
Weight: 34 lb (15 kg)



IN-2253

Wall adapter for concrete and steel

Compatible with mast IN-2426 or IN-2240 or IN-2313 and 48" (1219 mm) davit arm IN-2237
on existing concrete or steel structures. Anchor bolts not included.
*Allowable working angle.

Material: AISI 304 stainless steel also available in zinc plated steel (IN- 2303)
/ AISI 316 (IN-2468) and galvanized (IN-2528)
Dimensions: L 11" (279 mm) x W 7.4" (188 mm) x H 20" (508 mm)
Weight: 47 lb (21 kg)



48" | 1219_{mm}

Davit Arm with Adapters

IN-2516

Top wall adapter 90°

To be used over the edge of concrete structures with mast IN-2426 or IN- 2240 or IN-2313 and 48" (1219 mm) davit arm IN-2237.
Anchor bolts not included. *Allowable working angle.

Material: AISI 304 stainless steel

Dimensions: L 12" (305 mm) x W 15.4" (391 mm) x H 12" (305 mm)

Weight: 46 lb (21 kg)

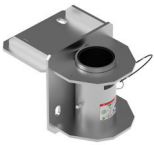

IN-2380

Adjustable barrel mount adapter

To be used on walls with 10" to 17" (254 mm to 432 mm) diameter thickness with mast IN-2426 or IN-2240 or IN-2313 and 48" (1219 mm) davit arm IN- 2237.
Equipped with eight spanners for correct torque
*Allowable working angle.

Material: zinc plated

Dimensions: L 12" (305 mm) x W 25.3"-30" (642-762 mm) x H 18" (456 mm)

Weight: 108 lb (49 kg)



A2238-03

Cylinder reduction 4" to 3" (102 mm to 76 mm)

Allows the use of masts IN-2003 on adapters meant for masts IN-2426, IN-2240 and IN-2313.

Material: Acetal delrin

Dimensions: ø 4" (102 mm) x H 8.75" (222 mm)

Weight: 2 lb (0.9 kg)





YELLOW.

The true colour of

SAFETY.

XTIRPA

48" | 1219

Davit Arm

with Universal T Base



Assembling scheme

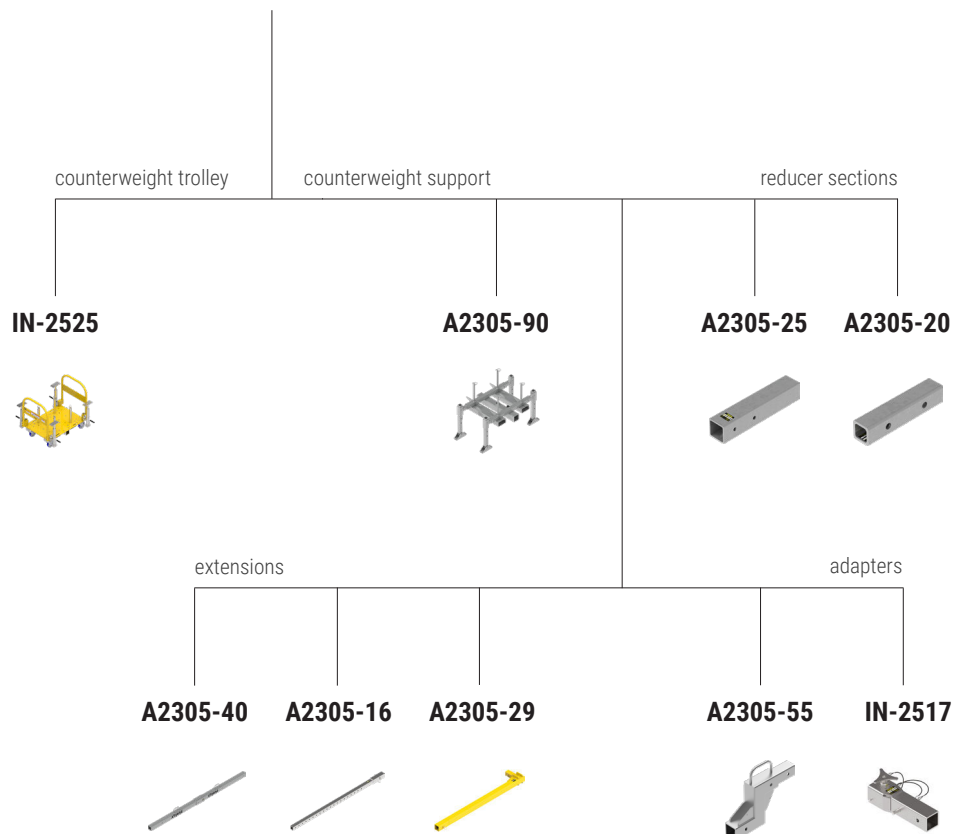
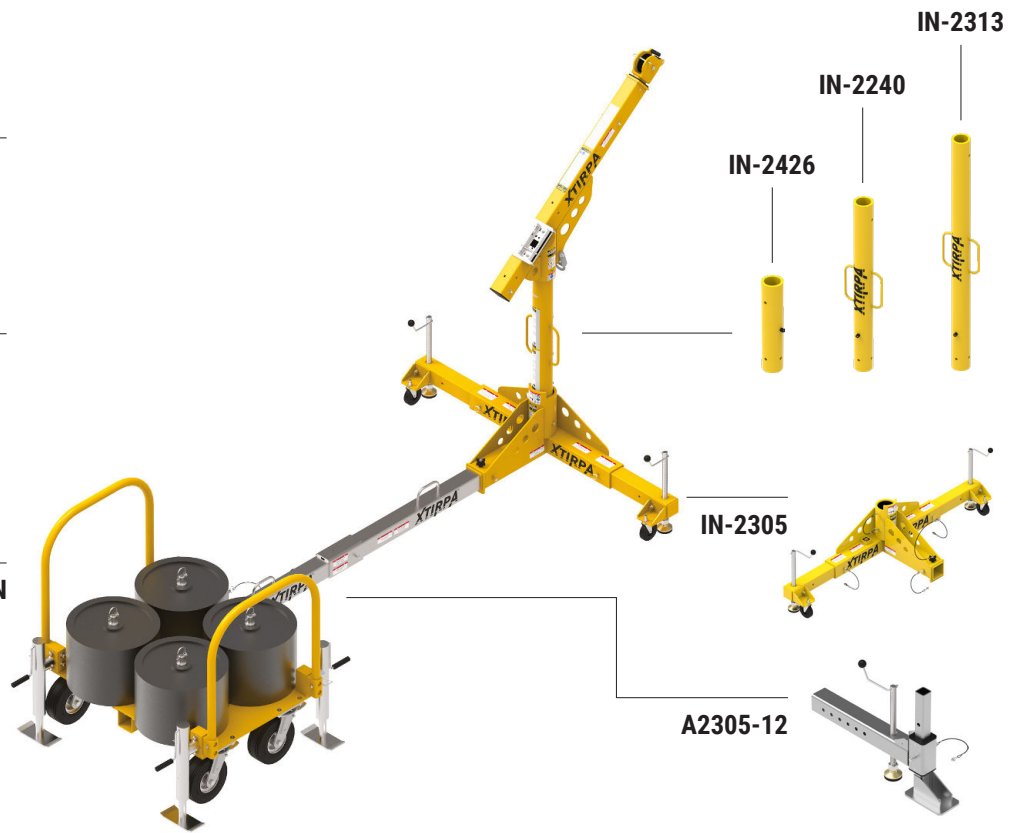

XTIRPA™

IN-2237 Davit Arm 1219 mm



Equipped with bracket for self-retracting lifeline to facilitate access to confined spaces. Compatible with mast IN-2426 or IN-2240 or IN-2313 and an appropriate adapter. Extensible to 30", 36" and 48" (762 mm, 914 mm and 1219 mm). Equipped with a 22kN anchor point.

Material:
Aluminium

Dimensions:
L 56"-77" (1422-1965mm)
W 6.8" (172 mm)
H 38.5"-52.2" (977-1326 mm)

Weight:
50 lb (23 kg)



IN-2426 / IN-2240 / IN-2313 Mast

Compatible with davit arm IN-2237 and corresponding adapters or with a counterweight system.

| Part | Length | Weight |
|---------|---------------|-----------------|
| IN-2426 | 20" (500 mm) | 11 lb (5 kg) |
| IN-2240 | 42" (1067 mm) | 23 lb (10.4 kg) |
| IN-2313 | 60" (1521 mm) | 34 lb (15.4 kg) |

Material: Aluminium



IN-2305 universal T Base

Compatible with mast IN-2426 or IN-2240 or IN-2313 and davit arm IN-2237. Equipped with screw-in stabilizer feet to simplify leveling operations and with wheels for ease of transport. *Allowable working angle.

Material: Aluminium

Dimensions: L 68.5" (1740 mm) x W 22" (559 mm) x H 18.7" (475 mm)

Weight: 73 lb (33 kg)

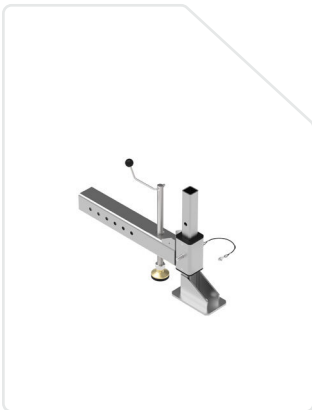

A2305-12 Portable anchor adapter

To be installed with corresponding threaded bar. Used with universal T base IN-2305.

Material: Steel

Dimensions: L 31.25" (794 mm) x W 5" (127 mm) x H 20.38" (518 mm)

Weight: 52 lb (23.6 kg)



IN-2525 Counterweight trolley

Compatible with the universal T base for trailer hitch IN-2305 and the extension A2305-40. Wheeled. Counter-weights sold separately.

Material: Steel

Dimensions: L 51.5" (1308 mm) x W 47.5" (1206 mm) x H 43" (1090 mm)

Weight: 497 lb (226 kg)

48" | 1219_{mm}

Davit Arm

with Universal T Base

P2525-018

weight plate

Compatible with IN-2525 and A2305-90 counterweight carts.



Material: Ductile Iron

Dimensions: 17-1/2" dia (446mm) x 1-1/4" (32mm) thick with 2" (51mm) center hole

Weight: 45 lb (20 kg)

P2525-019

weight plate

Compatible with IN-2525 and A2305-90 counterweight carts.



Material: Ductile Iron

Dimensions: 17-1/2" dia (446mm) x 1-5/8" (41mm) thick with 1" (25,4mm) center hole

Weight: 50 lb (23 kg)

A2305-90

Counterweight support

Compatible with the universal T base for trailer hitch IN-2305 and the extension A2305-40. Counter-weights sold separately.



Material: Zinc plated steel

Dimensions: L 47-49" (1181-1257 mm) x W 32" (813 mm) x H 25-34" (637-870 mm)

Weight: 185 lb (84 kg)

A2305-40

Extension for counterweight support

Additional Extension used to increase the distance between the counterweight support and the universal T base IN-2305.



Material: zinc plated steel

Dimensions: L 105" (2670 mm)

Weight: 97 lb (44 kg)

P2305-016N Counterweight plates

To be installed with the rods A2525-08 on the counterweight trolley IN-2525.
The number of required plates varies depending on the davit arm used.

Material: Steel
Dimensions: L 16" (406 mm) x W 12" (305 mm) x H 1" (25.4 mm)
Weight: 50 lb (22.7 kg)



P2525-017 Rounded counterweight plates

To be installed on the counterweight trolley IN-2525 or on the counterweight support A2305-90.
The number of plates required varies depending on the davit arm used.

Material: Steel
Dimensions: \varnothing 14.5" (368 mm) x H 1.9" (39.3 mm)
Weight: 50 lb (22.7 kg)



A2305-25 Reducer section for universal T Base

Compatible with universal T base IN-2305.
Allows the installation of the additional extension A2305-16 to the system.

Material: zinc plated steel
Dimensions: L 18" (457 mm) x W 3.4" (87 mm) x H 3.4" (87 mm)
Weight: 15 lb (7 kg)



A2305-16 Extension for hitch mount

Compatible with the universal T base IN-2305, when used with the anchor bolt adapter or with a vehicle.

Material: zinc plated steel
Dimensions: L 79" (2013 mm)
Weight: 49 lb (22 kg)



A2305-20 Reducer section for universal T Base

Compatible with universal T base IN.2305.
Allows the installation to north american vehicles.

Material: zinc plated steel
Dimensions: L 9.8" (248 mm) x W 2" (50.8 mm) x H 2" (50.8 mm)
Weight: 3 lb (1kg)



48" | 1219_{mm}

Davit Arm

with Universal T Base

A2305-29

Extension for 90° angle

Compatible with universal T base IN-2305. Allows the davit arm system with T-base to be used with the hitch mount at 90° in relation to the vehicle position. It must be used with the "Z" shaped adapter A2305-55.

Material: Zinc plated steel
Dimensions: L 60" (1524 mm) x W 10" (254 mm) x H 5" (127 mm)
Weight: 51 lb (23 kg)

A2305-55

Height adapter for universal T Base IN-2305

Compatible with universal T base IN-2305 and appropriate extension. It optimizes the system leveling depending on the vehicle height.

Material: zinc plated steel
Dimensions: L 3" (76 mm) x W 16.5" (419 mm) x H 13.2" (335 mm)
Weight: 21 lb (9.5 kg)

IN-2517

Hitch ball adapter for EU vehicles

This universal adapter allows the trailer hitch system to be used on most of the European vehicles.

Material: Zinc plated steel
Dimensions: L 13.25" (337 mm) x W 4" (102 mm)
Weight: 15 lb (6.8 kg)



PRODUCT BROCHURE

XTIRPA™



MODULAR SOLUTIONS

Confined Space



CONFINED SPACE ACCESS AND RESCUE SYSTEMS

ADVANCED DESIGN. EASY ASSEMBLY.

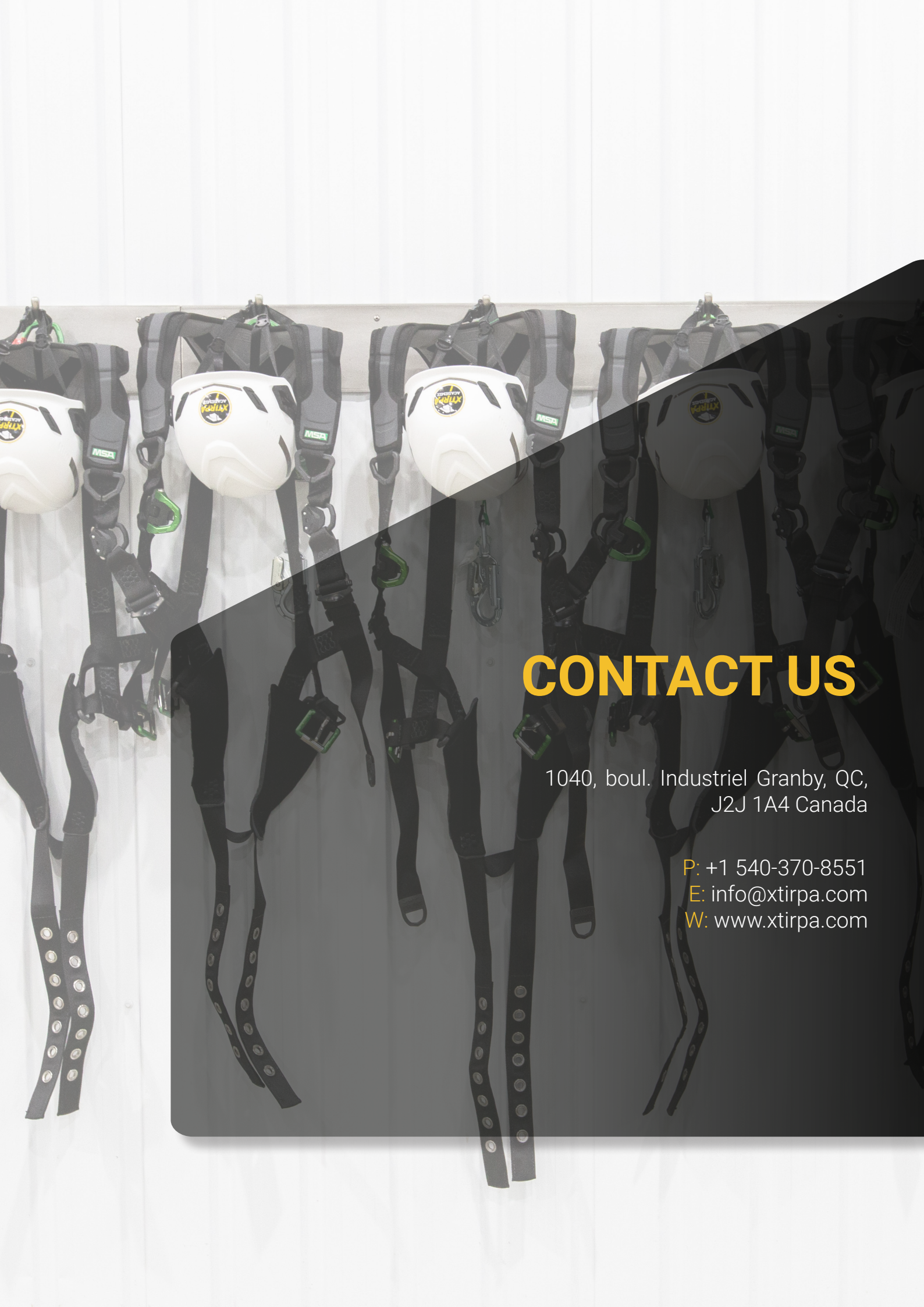

CONTACT US

1040, boul. Industriel Granby, QC,
J2J 1A4 Canada

P: +1 540-370-8551

E: info@xtirpa.com

W: www.xtirpa.com